

# HOUTTUIN 236 SERIES PUMPS

## TWO-SCREW PUMPS STANDARD PRODUCT SPECIFICATIONS

### PRODUCT PERFORMANCE YOU CAN RELY ON

The 236 series provides customers a time-tested, globally adopted self priming two screw pump suitable for low to mid range pressures and high compliance with API 676 3rd edition. The 236 offers:

- Rugged design for the harshest environments
- Field replaceable liner and 'pop-out' rotor access for ease of inspection and maintenance
- Optional suction and discharge alignments to match specific piping and system design needs

The 236 is suitable for a host of duties within process and transport applications for the chemical, food and beverage, oil and gas, petrochemical, shipbuilding and other general industries. It is available in a variety of materials, including cast and stainless steel, to meet your specific requirements (i.e. NACE).



**236 SERIES TWO-SCREW PUMP**

Up to 6,000 m<sup>3</sup>/h, 40 barg and viscosities from 0.6 cSt

### PRODUCT SPECIFICATIONS AND FEATURES

Casing and Covers	Ductile Iron, Cast Iron, Carbon or Stainless Steel (Type 300 or 400)
Rotors	Carbon or Stainless Steel (Type 300 or 400) (with optional hardening and plating)
Liner	Ductile iron, Cast iron, Ni-Resist, Bronze (with optional hardening and plating)
O-rings	Buna N, Viton or Teflon (in contact with pumped fluid), Nitrile (in contact with lubricating oil)
Shaft Sealing	Stuffing boxes, lip seals, single or double mechanical seals
Timing Gears	Spur or double helical
Bearings	Roller - internal or external
Flow rate range	Up to 6,000 m <sup>3</sup> /s (26,000 gpm)
Outlet pressure	Up to 40 barg (580 psi)
Inlet pressure	Up to 40 barg (580 psi)
Viscosity	0.6 - 5,000 cSt
Temperature	-5° C to 140° C (-20° F - 284° F)
Speed	Up to 2900 rpms
Drive	Direct, suitable for variable speed operations
Rotation	Clockwise facing pump driveshaft
Mounting	Horizontal
Port Connections	Per ANSI 150#, 300#, 600# or DIN PN16, PN24 - Locations: top, bottom, right, left
Accessories	Pressure relief valve, temperature and vibration monitors

**FLows < 1000 m³/h**  
MANAGED WITH 11 SIZES

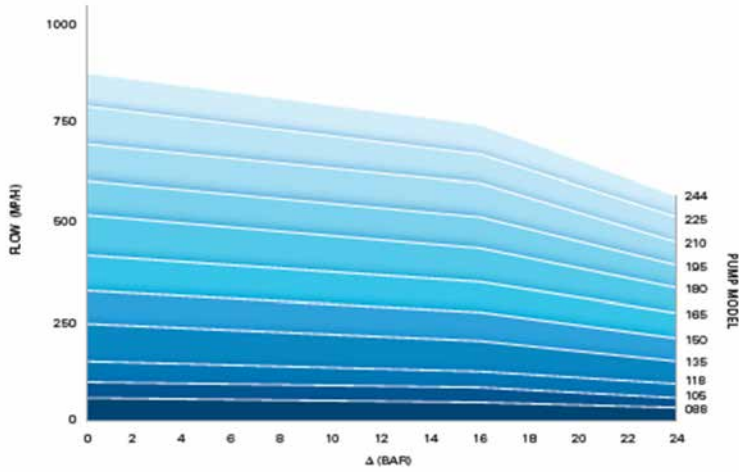

**FLows > 1000 m³/h**  
MANAGED WITH 6 SIZES

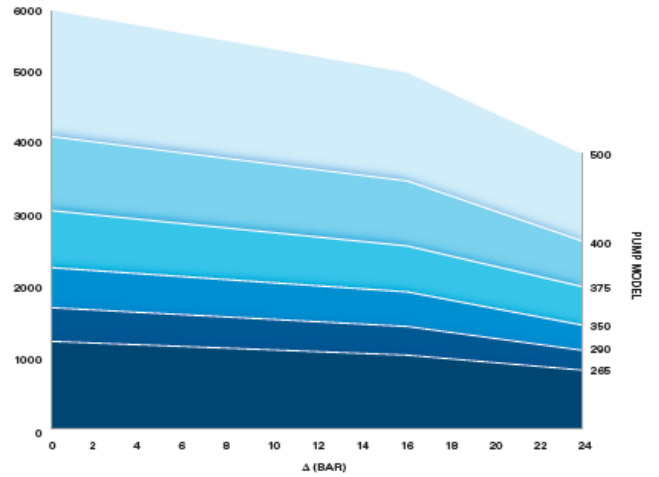

**APPROXIMATE STANDARD DIMENSIONS**

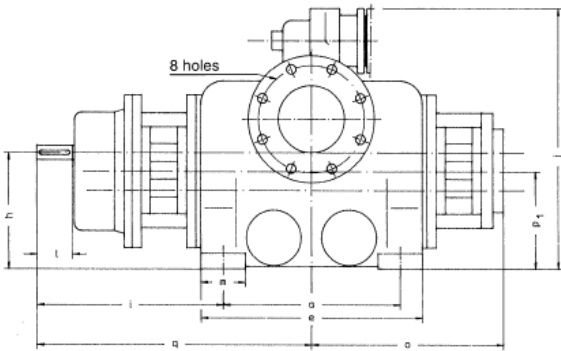

PUMP SIZE	PUMP FOOT DIMENSIONS								FLANGES PN		
088	325								228	46	
105	370	330	35	460	370	90	60	4x18	125	254	46
118	400	335	35	500	380	100	60	4x22	150	285	70
135	480	400	40	570	450	100	70	4x22	200	340	70
150	580	450	40	670	500	100	70	4x22	250	405	100
165	620	490	45	740	550	120	90	4x26	250	405	100
180	670	540	45	790	600	120	90	4x26	300	460	100
195	680	590	45	800	650	120	90	4x26	300	460	135
210	690	600	45	840	660	150	120	4x26	300	460	135
225	700	660	45	850	720	150	120	4x26	350	520	135

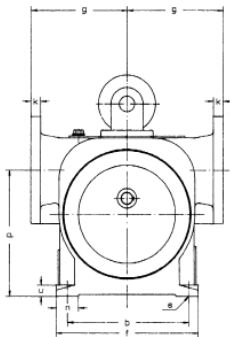

**Shaftend**

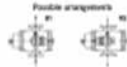
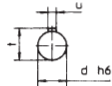

PUMP SIZE	PUMP DIMENSIONS								SHAFT END					WEIGHT KG (CA)
	g	h	i	j	k	o	p	p1	q	d	l	t	u	
088	230	230	362,5	488	26	380	305	197,5	525	28	60	31	8	165
105	240	245	375	506	26	400	310	207,5	560	28	60	31	8	220
118	250	260	400	610	26	429	335	218	600	32	80	35	10	275
135	275	280	405	655	30	465	355	233	645	38	80	41	10	380
150	300	305	410	805	32	525	400	252,5	745	42	110	45	12	535
165	320	335	500	832	32	576	425	277,5	810	45	110	48,5	14	760
180	350	355	515	897	32	610	465	292	850	50	110	53,5	14	965
195	370	375	520	983	32	627	480	307	860	55	110	59	16	1150
210	390	395	605	1025	32	666	520	321,5	950	60	140	64	18	1400
225	435	415	615	1070	36	677	540	336,5	965	65	140	69	18	1600

\*Dimensions not to be used for construction purposes

## SAMPLE INDUSTRIES AND FLUIDS

### CHEMICAL & PETROCHEMICAL

- Acids
- Additives
- Asphaltenes
- Glycerine
- Parrafin
- Polyethylene
- Fuel Oils
- Slops & Slurries
- Styrene
- Solvents

### SHIPBUILDING

- Fuel Oils
- Light Products
- Bilge/ballast Water
- Fresh/Sea Water
- Transfer Oils
- Crude Oils

### OIL & GAS

- Additives
- Asphaltenes
- Bitumen
- BS&Ws
- Crude Oil
- Distillation Fractions
- Fuel Oil
- Naphta
- Slops & slurries

### FOOD & BEVERAGE

- Animal Fats
- Filtrates
- Margarine
- Masse-cuite
- Molasses
- Soap - Stock
- Syrup
- Vegetable Oils

### OTHERS

- Aniline
- Benzene
- Caustic Soda
- Fatty Acids
- Glycerin
- Glycol
- Liquid Soaps
- Paper Pulp
- Phenol
- Gelatines
- Tar

## ADVANTAGES

- **API Pump:** high API 676 3rd edition compliance
- **High Efficiency:**

- **Easy Maintenance:** simplify inspections and maintenance with easy 'pop-out' rotor design
- **Customization:** optimally balance performance and costs with custom rotor pitches and profiles, seal types and suction/discharge locations
- **Rugged Design:** deliver consistent performance in harsh environmental with often drastic fluctuations in ambient or application conditions
- **Wear Protection:** limit pump wear with corrosion resistant materials, component hardening and specialized coatings
- **Low NPSH:** limit NPSHr with a free-flow suction flow path and field proven flow geometries



- **Bearings:** limit maintenance with oil lubricated, maintenance free ball bearings that provide dual radial and axial rotor support
- **Gears:** transmit torque safely with specialty hardened and ground oil-lubricated timing gears
- **PRV:** simplify installation and protect from pressure spikes with an integral pressure relief valve

### CIRCOR

1710 Airport Road  
 Monroe, NC 28110-5020  
 Tel: +1.704.289.6511  
 Tol: +1.877.853.7867

*Oil & Gas Products & Services*



ALLWEILER® HOUTTUIN™ IMO® ROSSCOR® WARREN®